



***XHD Lithium
Cordless Rotary
Hammer Drill
Brushless 18V -
Bare Tool***

TSC27



OPERATORS MANUAL



TABLE OF CONTENTS

Specifications	3
Product Identification	4
Safety Guidelines	5
Assembly	9
Operation	15
Maintenance	17

DISTRIBUTED BY:



Note:

This manual is for your reference only. Due to the continuous improvement of the XHD Lithium products, changes may be made at any time without obligation or notice.

Thank You

For the purchase of this XHD Lithium product. We try our hardest to supply customers like you with the best quality products available, at the best price possible. We cant wait to continue working together in the future.



SPECIFICATIONS

Voltage	18 Volts
No Load Speed	0-1400RPM
Hammer Power	2 Jules
Impact Rate	0-4500BPM
Chuck Type	SDS+
Drilling Capacity:	Concrete: 22mm
	Steel: 13mm
	Wood: 28mm
Total Length	300mm

PRODUCT IDENTIFICATION



- 1 Depth Stop Housing
- 2 Depth Stop Gauge
- 3 Action Mode Changing Knob
- 4 Reverse Switch Lever
- 5 ON/OFF Trigger
- 6 Ergonomic Rubber Handle
- 7 LED Work Light
- 8 Side Auxiliary Handle
- 9 SDS+ Drill Chuck
- 10 Chuck Cover
- 11 XHD Battery (Not Included)

SAFETY GUIDELINES

WARNING

READ ALL SAFETY WARNINGS & INSTRUCTIONS. Failure to follow instructions and warnings could lead to serious injury, electric shock, or fire.

Work Area Safety

- **Ensure that your work area is kept clean and well lit.** Lack of visibility and clutter greatly increase the risk of accident when using tools.
- **Keep bystanders, pets, and children clear when operating this power tool or machine.** They can cause distraction or risk injury to themselves.
- **Ensure you are not operating the power tool or machinery in the presence of dust, liquids, flammable gases, or anything that can create an explosive atmosphere.** Power tools and machinery can create sparks which can lead to ignition and fire hazards in working environments.

Personal Safety

- **Always wear personal protective equipment (PPE).** Eye protection, ear protection, dust masks, and other protective equipment will help to reduce the risk of personal injury or long-term illnesses.
- **Dress appropriately. DO NOT wear loose clothing that can get caught in moving parts.** Keep hair, loose clothing, jewellery, and anything else that could be of risk, away

from moving parts in the machine, or they could become caught therein.

- **Always remain alert and DO NOT operate power tools or machinery under the influence of any substances such as alcohol or drugs, including prescription medications.** Lack of focus could lead to injury or accidents while operating these power tools and machinery.
- **Always ensure proper footing and balance.** Overreaching can lead to slipping and falling which can result in injury or accident.
- **Ensure the power switch is in the OFF position before connecting any battery, or power source to the power tool or machinery.** This can cause injury as tools and machinery can suddenly fire incidentally when live, causing accidents.
- **Use all provided dust collection and extraction attachments, if included.** This equipment, along with the use of PPE dust masks, can help keep you safe from dust inhalation, and keep your work site clear from hazards.
- **Ensure loose parts such as wrenches or adjusting keys are removed before starting the power tool or machinery.**



SAFETY GUIDELINES

Power Tool & Machinery Use & Care

- **Use the correct tool for the job.** Forcing a tool to do a job it was not designed for increases the risk of accident or injury.
- **Disconnect tools and machinery from power, or remove batteries before doing any maintenance or adjustments, or before storing the tools and machinery.** This reduces or removes the risk of a power connection that causes the tool or machinery to accidentally fire, which can help prevent injury or accident.
- **Check the general condition of the power tool for damage or any problems that could affect the way the tool or machine works.** An unrepaired tool or machine can lead to accident and injury. Only have your tool or machine repaired with genuine parts from your local distributor
- **Only use the power tool and machinery with genuine parts or accessories that are designed to be used with this power tool and machinery.** Failure to do so could result in accident or injury, or damage your tool or machinery.
- **Store your tool or machinery out of reach of children, and away from untrained personnel when not in use.** Use by somebody untrained, or a child, could lead to accident or serious injury.

Service

- **Have your tools and machinery serviced by your local distributor with genuine XHD Lithium replacement parts.** This will ensure that the safety of the power tool or machine is maintained.



WARNING

The warnings and precautions discussed in this manual cannot cover all possible conditions and situations that may occur. It must be understood by the operator that common sense and caution are factors which cannot be built into this product, but must be supplied by the operator.

Always Use Common Sense

- It is not possible to cover every conceivable situation you can face. Always exercise care and use your common sense. If you get into a situation where you feel unsafe, stop and seek expert advice. Contact your dealer, service agent, or an experienced user. Do not attempt any task you feel unsure of!
- **Do not let familiarity gained from the frequent use of tools allow you to become complacent and ignore tool safety principles.** A careless action can cause severe injury within a fraction of a second.



SAFETY GUIDELINES

Battery Tool Use & Care

- Prevent unintentional starting. Ensure the switch is in the OFF position before connecting to the battery pack, picking up, or carrying the machine. Carrying the machine with your finger on the switch or energising a machine that has the switch ON invites accidents.
- Disconnect the battery pack from the machine before making any adjustments, changing accessories, or storing the machine. Such preventive safety measures reduce the risk of starting the machine accidentally.
- Recharge the battery only with the charger specified by the manufacturer. A charger that is suitable for one type of battery pack may create a risk of fire when used with another battery pack.
- Use machines only with specifically designated battery packs. Use of any other battery packs may create a risk of injury and fire.
- When the battery pack is not in use, keep it away from other metal objects, like paper clips, coins, keys, nails, screws, or small metal objects, that can make a connection from one terminal to another. Shorting the battery terminals together may cause burns or a fire.
- Under abusive conditions, liquid may be ejected from the battery; avoid contact. If contact accidentally occurs, flush the area with water. If liquid contacts eyes, seek medical help. Liquid ejected from the battery may be acidic and may cause irritation or burns.
- Do not use a battery pack or machine that is damaged or modified. Damaged or modi-

fied batteries may exhibit unpredictable behaviour resulting in fire, explosion, or risk of injury.

- Do not expose a battery pack or machine to fire or excessive temperature. Exposure to fire or temperature above 130°C may cause explosion.
- Follow all charging instructions and do not charge the battery pack or machine outside of the temperature range specified in the instructions.
- Charging the battery improperly, or at temperatures outside of the specified range may damage the battery and increase the risk of fire.
- Have servicing performed by a local XHD distributor repair person using only identical replacement parts. This will ensure that the safety of the product is maintained.
- Do not modify or attempt to repair the machine or the battery pack except as indicated in the instructions for use and care.

Battery Long Life Tips

- Charge the battery cartridge before it is completely discharged. Always stop tool operation and charge the battery cartridge when you notice less tool power.
- Never recharge a fully charged battery cartridge. Overcharging shortens the battery service life.
- Charge the battery cartridge with room temperature at 10°C – 40°C. Allow a hot battery cartridge to cool before charging it.
- Charge the battery cartridge once in every six months if you do not use it for extended periods at a time.

SAFETY GUIDELINES

Hammer Drill Specific Safety

- Wear ear protectors. Exposure to excessive noise can cause hearing loss.
- Use auxiliary handle(s), if supplied with the tool. Loss of control can cause personal injury.
- Hold power tool by insulated gripping surfaces, when performing an operation where the cutting accessory may contact hidden wiring. Cutting accessory contacting a “live” wire may make exposed metal parts of the power tool “live” and could give the operator an electric shock.
- Wear a hard hat (safety helmet), safety glasses and/or face shield. Ordinary eye or sun glasses are NOT safety glasses. It is also highly recommended that you wear a dust mask and thickly padded gloves.
- Wear Steel Capped Shoes to protect your feet from the downward action of the drill and any debris.
- Be sure the bit is secured in place prior to operation.
- Under normal operation, the tool is designed to produce vibration. The screws can come loose easily, causing a breakdown or accident. Check the tightness of screws carefully prior to operation.
- In cold weather or when the tool has not been used for a long time, let the tool warm up for a while by operating it under no load. This will loosen up the lubrication. Without proper warm-up, hammering can be difficult.
- Always be sure you have a firm footing. Be sure no one is below when using the tool in high locations.
- Hold the tool firmly with both hands.
- Keep hands away from moving parts.
- Do not leave the tool running. Operate the tool only when hand-held.
- Do not point the tool at any one in the area when operating. The bit could fly out and seriously injure someone.
- Do not touch the bit, parts close to the bit, or the workpiece immediately after operation; they may be extremely hot and can burn you.
- Withdraw the drill often to clear the dust and debris from the hole; this will help to prevent jamming.
- Keep the air vents on the machine clear and unblocked.
- This is a powerful tool; switch it off if the tool sticks or seems unsafe. If the drill sticks, stop the machine and unwind it by hand.
- During extended use, rotary hammers and hammer drills can cause vibration fatigue to the operator. Regular breaks should be scheduled to prevent fatigue from becoming a hazard to the operator.
- Only use the appropriate SDS+ drill type for the machine; standard drill bits may shatter creating a safety hazard.
- **Reduce the dust pollution.** Particles caused by working with the Rotary Hammer Drill may contain materials which can cause cancer, allergic reactions, respiratory illnesses, birth defects or other reproductive damage. Some examples of these materials are: Lead, mineral dust, additives in wood treatment agents (chromate, wood protection agents), some types of wood (such as oak or beech dust), metals, asbestos.

ASSEMBLY

CAUTION

Always be sure that the machine is switched off and the battery cartridge is removed before assembling or disassembling the machine or bits.

CAUTION

Hold the machine and the battery cartridge firmly when installing or removing the battery. Failure to do so may cause them to slip off your hands and result in damage to the machine, battery cartridge, or a personal injury.

Always install the battery cartridge fully until the red indicator light cannot be seen. If not, it may accidentally fall out of the tool.

Do not install the battery cartridge forcibly. If the cartridge does not slide in easily, it is not being inserted correctly.

Installing & Removing the Battery Cartridge

- To remove the battery cartridge, slide it from the tool while sliding the button on the front of the cartridge.
- To install the battery cartridge, align the tongue on the battery cartridge with the groove in the housing and slip it into place. Insert it all the way until it locks in place with

a little click. If you can see the red indicator on the upper side of the button, it is not locked completely.

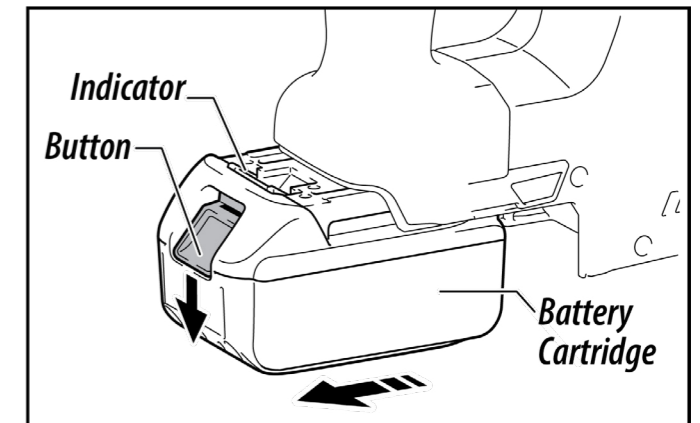

Indicating the Remaining Battery Capacity

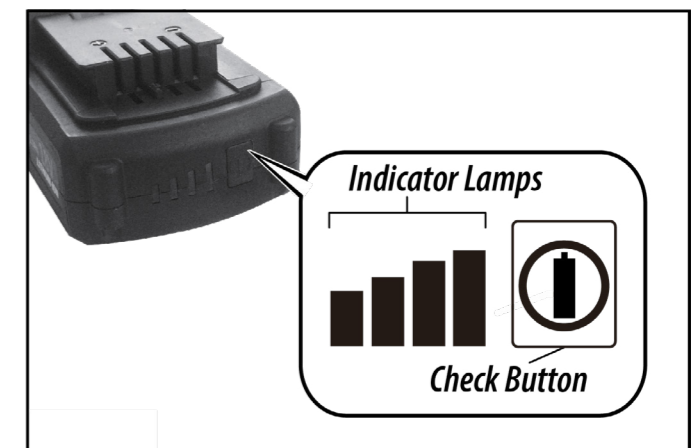

- Press the check button on the battery cartridge to indicate the remaining battery capacity. The indicator lamps light up for few seconds.

NOTE: Depending on the conditions of use and the ambient temperature, the indication may differ slightly from the actual capacity.

ASSEMBLY

INDICATOR LAMPS			REMAINING CAPACITY
LIGHTED	OFF	BLINKING	
■	□	▧	
■ ■ ■ ■			75% to 100%
■ ■ ■ □			50% to 75%
■ ■ □ □			25% to 50%
■ □ □ □			0% to 25%
▧ □ □ □			Charge the Battery.
■ ■ □ □			The Battery may have Malfunctioned
□ □ ■ ■			

Tool/Battery Protection System

- The tool is equipped with a tool/battery protection system. This system automatically cuts off power to the motor to extend tool and battery life. The tool will automatically stop during operation if the tool or battery is placed under one of the following conditions:

Overload Protection

- When the battery is operated in a manner that causes it to draw an abnormally high current, the tool automatically stops without any indication. In this situation, turn the tool off and stop the application that caused the tool to become overloaded. Then turn the tool on to restart.

Overheat Protection

- When the tool or battery is overheated, the tool stops automatically and the lamp blinks. In this case, let the tool and battery cool before turning the tool on again.

Over Discharge Protection

- When the battery capacity is not enough, the tool stops automatically. In this case, remove the battery from the tool and charge the battery.

Switch Action

- To start the tool, simply pull the switch trigger. Tool speed is increased by increasing pressure on the switch trigger. Release the switch trigger to stop.



Switch Trigger

ASSEMBLY

Illuminating the Work Light

CAUTION

Do not look in the light or see the source of light directly.

- Pull the switch trigger to illuminate up the light. The lamp keeps on lighting while the switch trigger is being pulled. The lamp will go out approximately 10 seconds after releasing the switch trigger.

NOTE: Use a dry cloth to wipe the dirt off the lens of the lamp. Be careful not to scratch the lens of lamp, or it may lower the illumination.

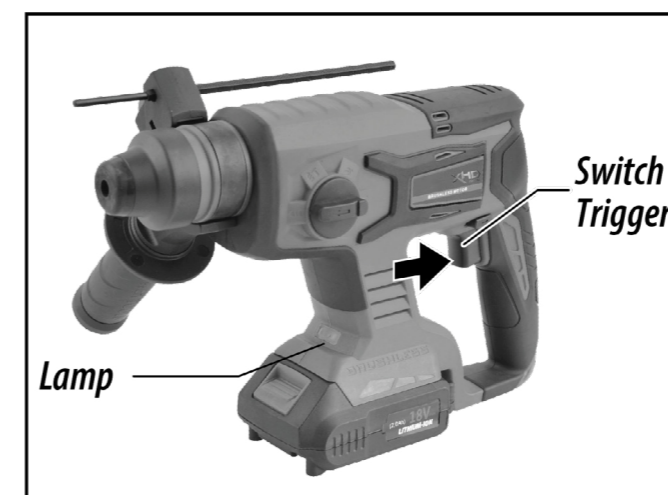

Lamp

Switch Trigger

Reversing Switch Action

CAUTION

Always check the direction of rotation before operation.

Use the reversing switch only after the tool comes to a complete stop. Changing the direction of rotation before the tool stops may damage the tool.

When not operating the tool, always set the reversing switch lever to the neutral position.



Reversing Switch Lever

- This tool has a reversing switch to change the direction of rotation. Depress the reversing switch lever from the 'A' side for clockwise rotation or from the 'B' side for counter-clockwise rotation.
- When the reversing switch lever is in the neutral position, the switch trigger cannot be pulled.

ASSEMBLY

Selecting the Action Mode

NOTICE

Do not rotate the Action Mode Changing Knob when the tool is running. The tool will be damaged.

To avoid rapid wear on the mode change mechanism, be sure that the action mode changing knob is always positively located in one of the action mode positions.

Electric Brake

- This tool is equipped with an electric brake. If the tool consistently fails to quickly stop after the switch trigger is released, consult your local XHD distributor for advise.

Drilling with Hammering

- For drilling in concrete, masonry, etc., rotate the action mode changing knob to the symbol. Use a carbide-tipped drill bit.

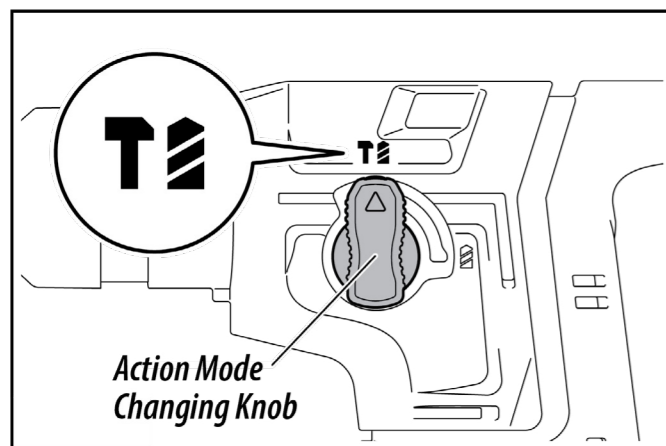

Drilling Only

- For drilling in wood, metal, or plastic materials, rotate the Action Mode Changing Knob to the symbol. Use a twist drill bit or wood drill bit.

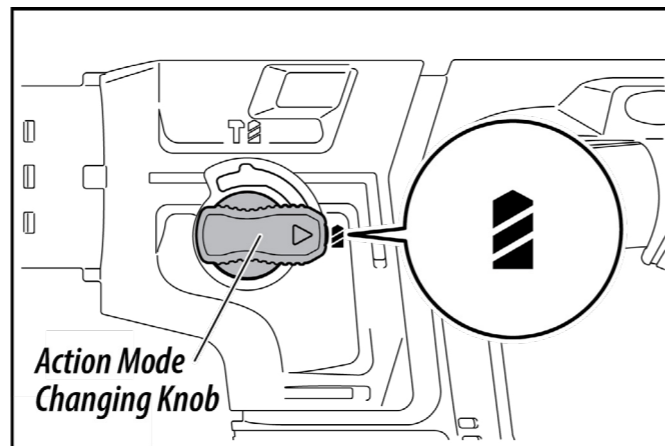

Hammer Only

- For chipping, scaling or demolition operations, rotate the action mode by changing the knob to the symbol. Use a bull point, cold chisel, scaling chisel, etc.

Hammer Action with Bit Locked In Position

- In this mode , the chisel bit is locked in a fixed position, preventing it from rotating. This mode is particularly useful for shaping materials because it gives you greater control over where and how the chisel makes contact.

ASSEMBLY

Side Grip (Auxiliary Handle)

CAUTION

Always use the side grip to ensure safe operation.

After installing or adjusting the auxiliary handle, ensure that the side grip is properly secured.

- Install the auxiliary handle so that the grooves on the grip fit in the protrusions on the tool barrel. Turn the grip clockwise to secure it. The grip can be fixed at your desired angle.

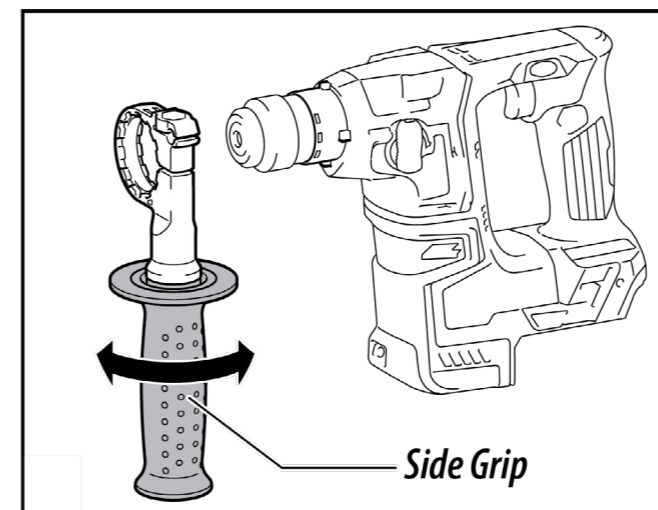

Grease

- Coat the shank end of the drill bit beforehand with a small amount of grease (about 0.5–1g). This chuck lubrication assures smooth action and longer service life.

Installing or Removing Drill Bits

- Clean the shank end of the drill bit and apply grease before installing the drill bit.

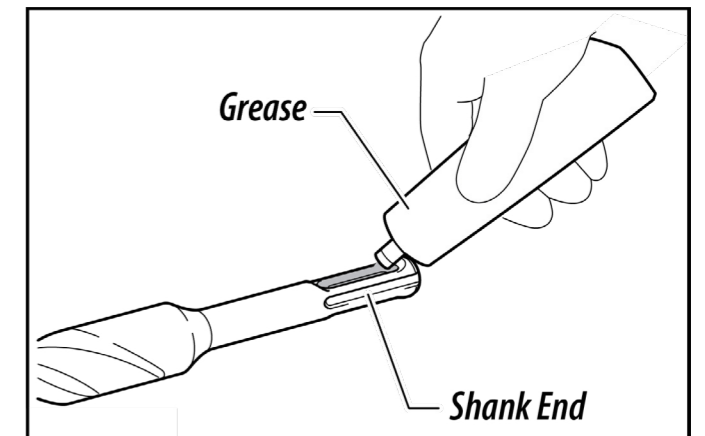

- Insert the drill bit into the tool. Turn the drill bit and push it in until it engages.
- After installing the drill bit, always make sure that the drill bit is securely held in place by trying to pull it out.

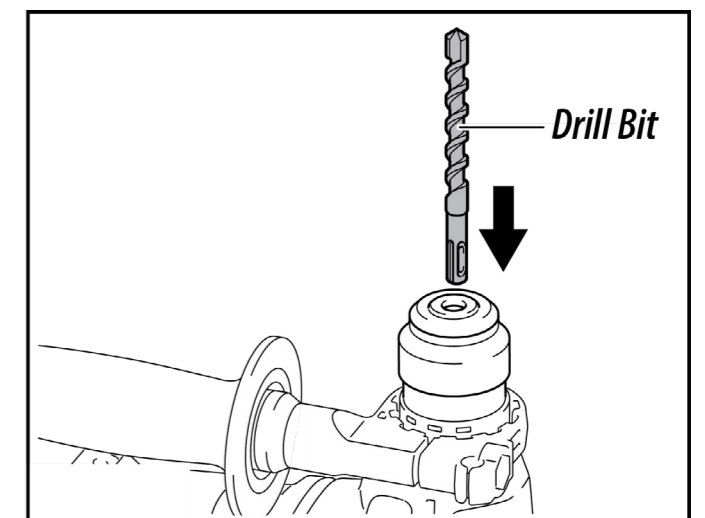

ASSEMBLY

- To remove the drill bit, pull the chuck cover down all the way and pull the drill bit out.

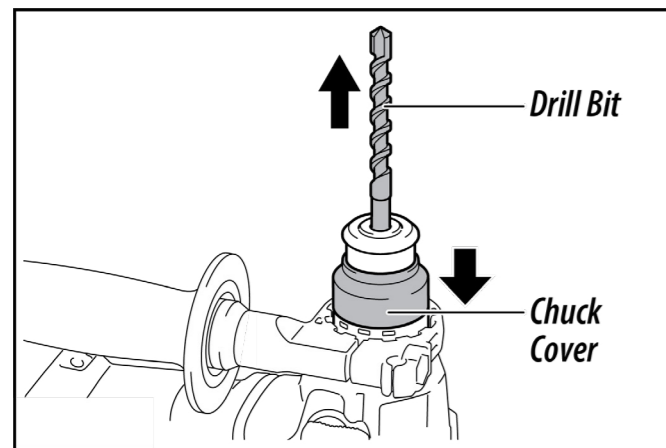

Depth Gauge

- The depth gauge is convenient for drilling holes of uniform depth. Loosen the side grip and insert the depth gauge into the hole on the side grip. Adjust the depth gauge to the desired depth and tighten the side grip firmly.

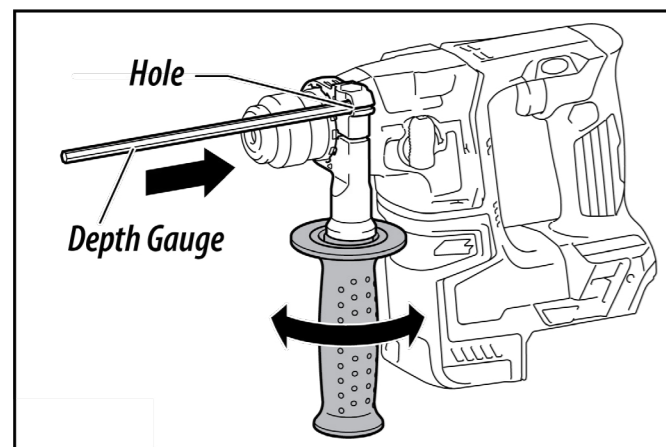

NOTE: Make sure that the depth gauge does not touch the main body of the tool when attaching it.

Hanging Hook

CAUTION

Always remove the battery when hanging the tool with the hook.

Never hook the tool at a high location or on a potentially unstable surface.

- The hook is convenient for temporarily hanging the tool. This can be installed on either side of the tool.
- To install the hook, insert it into the groove in the tool housing on either side and then secure it with a screw.
- To remove, loosen the screw and then take it out.

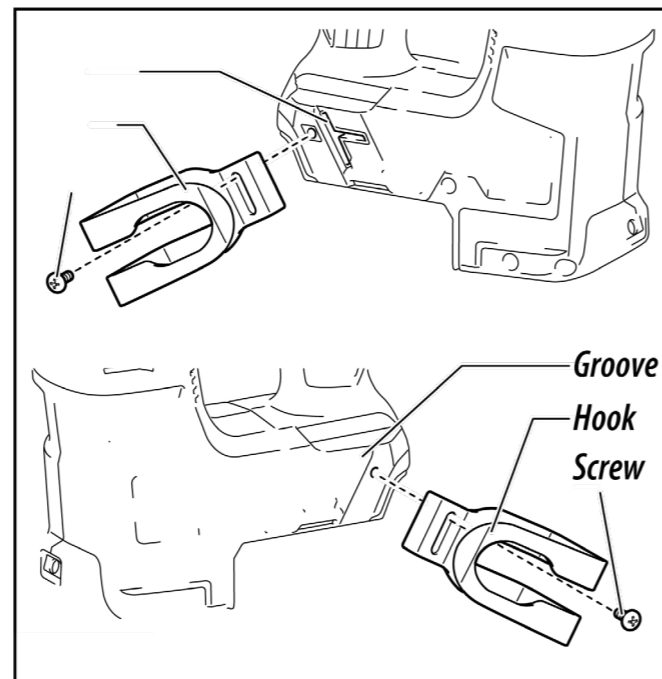

OPERATION

CAUTION

Always use the side grip (auxiliary handle) and firmly hold the tool by both the side grip and switch handle during operations.

Always make sure that the workpiece is secured before operation.

Hammer Drilling Operation

NOTE: If the battery cartridge is in low temperature, the tool's capability may not be fully obtained. In this case, warm up the battery cartridge by using the tool with no load for a while to fully obtain the tool's capability.

CAUTION

There is tremendous and sudden twisting force exerted on the tool/drill bit at the time of hole break-through, when the hole becomes clogged with chips and particles, or when striking reinforcing rods embedded in the concrete. Always use the auxiliary handle and firmly hold the tool by both the side handle and switch handle during operations. Failure to do so may result in the loss of control of the tool and potentially severe injury.

- Set the Action Mode Changing Knob to the symbol.
- Position the drill bit at the desired location for the hole, then pull the switch trigger. Do not force the tool. Light pressure gives best results. Keep the tool in position and prevent it from slipping away from the hole.
- Do not apply more pressure when the hole becomes clogged with chips or particles. Instead, run the tool at an idle, then remove the drill bit partially from the hole.
- By repeating this several times, the hole will be cleaned out and normal drilling may be resumed.

NOTE: Eccentricity in the drill bit rotation may occur while operating the tool with no load. The tool automatically centres itself during operation. This does not affect the drilling precision.

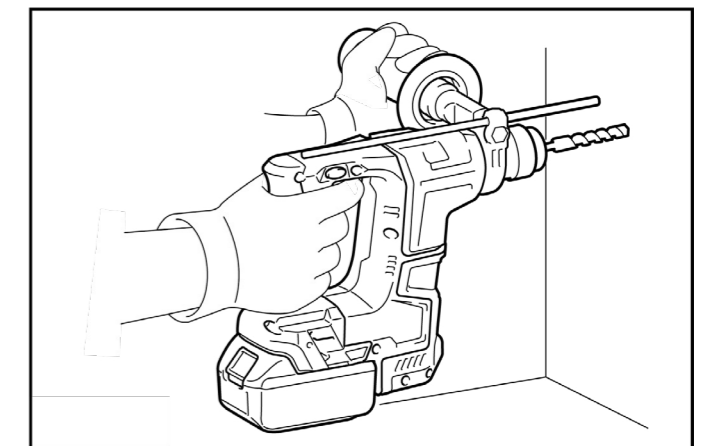

OPERATION

Drilling In Wood or Metal

CAUTION

Hold the tool firmly and exert care when the drill bit begins to break through the workpiece. There is a tremendous force exerted on the tool/drill bit at the time of hole break through.

A stuck drill bit can be removed simply by setting the reversing switch to reverse rotation in order to back out. However, the tool may back out abruptly if you do not hold it firmly.

- Set the Action Mode Changing Knob to the  symbol.
- Attach the chuck adapter (sold separately) to a keyless drill chuck to which 1/2"-20 size screw can be installed, and then install them to the tool. When installing it, refer to the section "Installing or Removing Drill Bits" on Page 13.

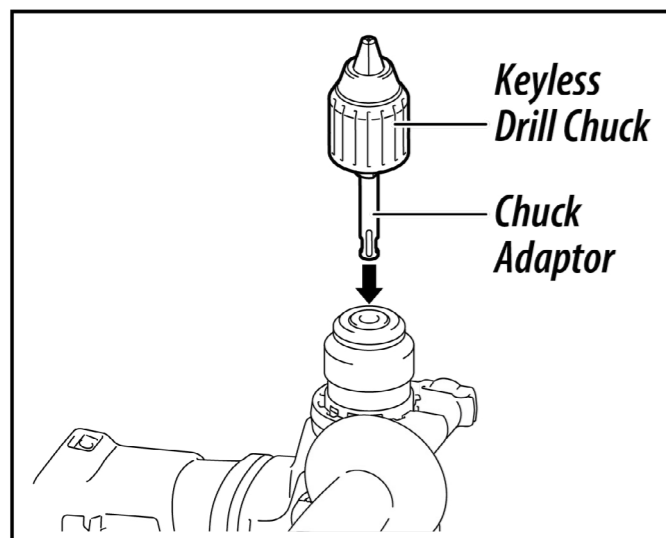

NOTICE

Never use "Rotation With Hammering" when the drill chuck is installed on the tool. The drill chuck may be damaged. Also, the drill chuck will come off when reversing the tool.

Pressing excessively on the tool will not speed up the drilling. In fact, this excessive pressure will only serve to damage the tip of your drill bit, decrease the tool performance and shorten the service life of the tool.

MAINTENANCE

- Before cleaning or performing any maintenance, you must ensure the tool is switched off and disconnected from the power supply.
- Compressed air is the most effective way to clean this tool. Always wear PPE safety goggles when cleaning tools with compressed air.
- Ventilation openings and switch levers must be kept clean. DO NOT attempt to clean by inserting pointed objects through openings.
- Do not use harsh chemicals or solvents when cleaning this tool. Never use gasoline, benzine, thinner, alcohol or the like. Discoloration, deformation or cracks may result.
- If you discover any damaged or broken parts, consult your local XHD distributor for replacements and advise.

WARNING

Always be sure that the tool is switched off and the battery removed before attempting to perform any inspection or maintenance.

Environment & Disposal

- Packaging materials are raw materials and can be re-used. Separate the different packaging materials and take them to the appropriate waste disposal facility. More information can be obtained from your local authorities.
- Old machines do not belong in your household garbage! Dispose of old machines appropriately, we are all responsible for the environment.